

# **66-Channel GPS Module**

*with MTK Chipset*

## **GP-3711**

*Low power consumption version*

# GP-3711 Data Sheet

History		
Date	Rev.	Description
2013/12/31	A00	First Release

## Description

The GP-3711 is a ROM-based mini GPS module which is special designed for ultra low power consumption purpose environment. It is a GPS receiver providing a solution that high position and speed accuracy performances as well as high sensitivity and tracking capabilities in urban conditions. This mini module has extremely small size (**only 11.5mm x 11.5mm area**). The GPS chipsets inside the module are designed by **MediaTek Inc.**, which is the world's leading digital media solution provider and largest fab-less IC company in Taiwan. The module can support up to **66 channels**. The GPS solution enables small form factor devices. They deliver major advancements in GPS performances, accuracy, integration, computing power and flexibility. They are designed to simplify the embedded system integration process.

## Features

- ✦ Based on **MediaTek** Single Chip Architecture (MT3337).
- ✦ ARM7 based application processor
- ✦ High sensitivity: -165dBm tracking
- ✦ L1 frequency, C/A code
- ✦ Multi-tone active interface canceller (MTAIC)
- ✦ Channels: 66 acquisition, 22 simultaneous tracking
- ✦ Low power consumption: 26mA @ acquisition, 22mA @ tracking
- ✦ Cold/Warm/Hot start time: <35/<34/<1 seconds
- ✦ Maximum fixed update rate up to **5Hz**
- ✦ GPS data interface: TTL level serial port
- ✦ Support NMEA 0183 standard V3.01 and backward compliance
- ✦ Support SBAS – WAAS, EGNOS, GAGAN and MSAS
- ✦ Dimension : **11.5mm x 11.5mm x 2.15mm**
- ✦ SMD TYPE
- ✦ RoHS compliant
- ✦ Advanced software features
  - AlwaysLocate™ advanced location awareness technology
  - EPO™ orbit prediction
  - Supports logger function (LOCUS)

## Chipset Characteristics

<b>General</b>	
Chipset	MTK MT3337
Frequency	L1, 1575.42MHz
C/A Code	1.023 MHz
Channels	66 channels
SBAS	WAAS, EGNOS, GAGAN,MSAS Supported
Datum	WGS84(Default), Tokyo-M, Tokyo-A, User Define
CPU	ARM7EJ-S
<b>Dimensions</b>	
Length/Width/Height	26*26*11.7 mm
Weight	12 g
<b>Performance Characteristics</b>	
Position Accuracy	Without aid : 3.0m 2D-RMS
	< 3m CEP (50%) without SA (horizontal)
	DGPS (RTCM, SBAS (WAAS, EGNOS, MSAS)) : 2.5m
Velocity Accuracy	Without aid : 0.1 m/s
	DGPS (RTCM, SBAS (WAAS, EGNOS, MSAS)) : 0.05m/s
Acceleration Accuracy	Without aid : 0.1 m/s <sup>2</sup>
	DGPS (RTCM, SBAS (WAAS, EGNOS, MSAS)) : 0.05m/s <sup>2</sup>
Timing Accuracy	100 ns RMS
<b>Sensitivity</b>	Acquisition : -148dBm (Cold Start)
	Reacquisition : -163dBm
	Tracking : -165dBm
Maximum fixed Update Rate	Up to 5Hz(Default: 1Hz)
<b>Acquisition (Open sky, stationary)</b>	
Reacquisition Time	Less than 1 second
Hot start	1.0s (Typical)
Warm start	34s (Typical)
Cold start	35s (Typical)
<b>Dynamic</b>	

## GP-3711 Data Sheet

Rev.A00

Altitude	Maximum 18,000m
Velocity	Maximum 515m/s
Acceleration	Maximum 4G
<b>Power</b>	
Input Voltage	DC 3.3V Typical
Power Consumption @ 3.3V	Acquisition : 26mA Typical
	Tracking : 22mA Typical
<b>I/O</b>	
Signal Output	TTL level, 8 data bits, no parity, 1 stop bit
Available Baud Rates	4800/9600/38400/115200 bps(Default : 9600)
Protocols	NMEA 0183 v3.01 (Default : GGA,GSA,GSV,RMC,VTG) RTCM MTK NMEA Command Network Assistance Messages
<b>Data output Interface</b>	
Protocol messages	9600 bps/8/N/1 (Default)
Output format	GGA(1sec),GSA(1sec),RMC(1sec),VTG(1sec), GSV(5sec) (Default)
<b>Environment</b>	
Operating Temperature	-45 °C to 85 °C
Storage Temperature	-50 °C to 125 °C
Operating Humidity	5% to 95% (no condensing)

## Dimension

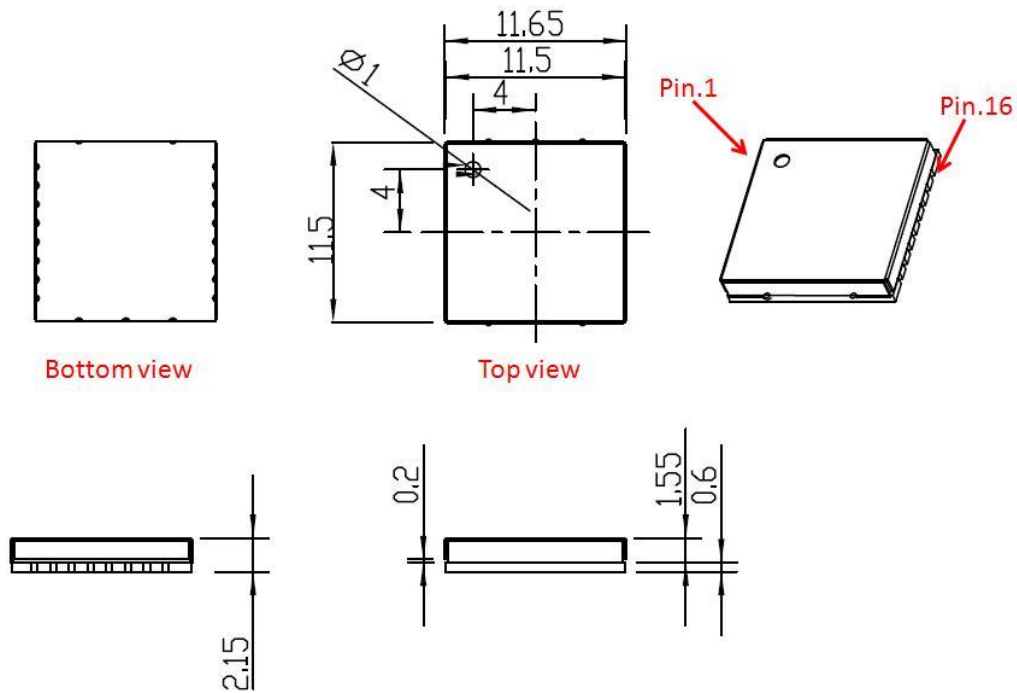

## Recommended PCB Layout

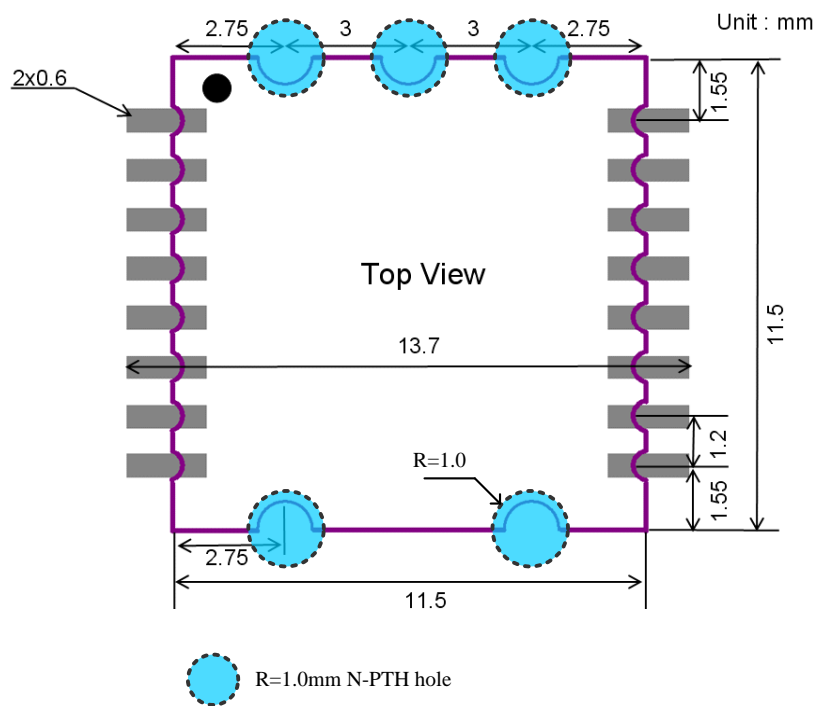

## Pin Configuration

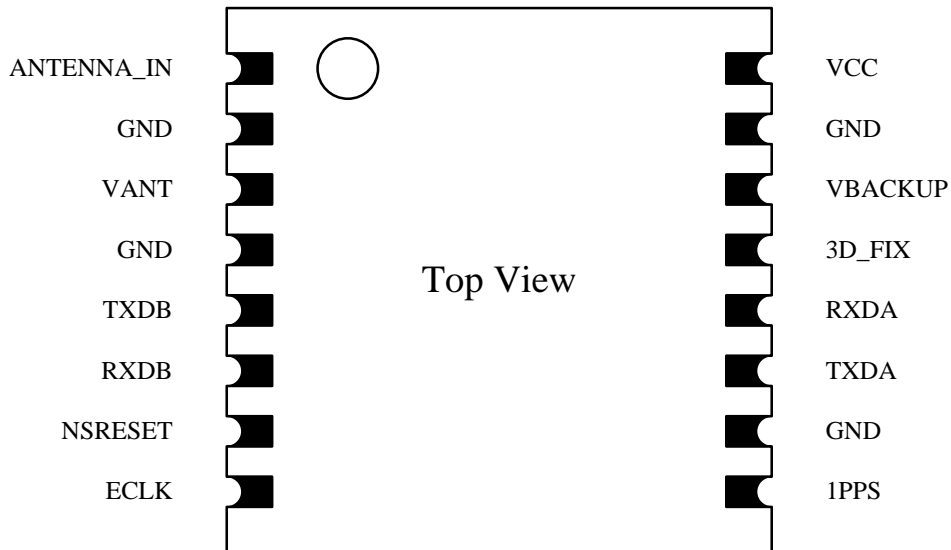

## Pin Definition

Pin	Name	I/O	Description
1	ANTENNA_IN	I	Antenna Signal Input
2	GND	P	Ground
3	VANT	PI	External Antenna Power Supply Input
4	GND	P	Ground
5	TXDB	O	Serial Data Output B
6	RXDB	I	Serial Data Input B
7	NSRESET	I	System Reset. Active low
8	ECLK	I	External Clock Input
9	1PPS	O	1 pulse-per-second GPS time reference
10	GND	P	Ground
11	TXDA	O	Serial Data Output A
12	RXDA	I	Serial Data Input A
13	3D_FIX	O	3D_Fix Indicator
14	VBACKUP	PI	RTC Backup Power Input
15	GND	P	Ground
16	VCC	P	3.3V $\pm$ 10% DC Power Supply Input

## Description of I/O Pin

# GP-3711 Data Sheet

Rev.A00

## **ANTENNA\_IN (Pin1)**

GPS RF signal input. With the power supply from pin3 VANT, this pin can output a DC voltage for external active antenna.

## **GND (Pin2, 4, 10, 15)**

The ground of the module.

## **VANT (Pin3)**

The power supply input for external active antenna. The input voltage should be kept from 2.5V to 5.0V.

## **TXDB (Pin5)**

This is the UART-B transmitter of the module. It is used for aiding. If not used, keep floating.

## **RXDB (Pin6)**

This is the UART-B receiver of the module. It is used for aiding. If not used, keep floating.

## **NSRESET (Pin7)**

With a low level, it causes the module to reset. If not used, keep floating.

## **ECLK (Pin8)**

This pin is used for clock correcting in AGPS. Not used, keep floating.

## **1PPS (Pin9)**

1 pulse-per-second GPS time reference output

## **TXDA (Pin11)**

This is the UART transmitter of the module. It outputs the GPS information for application.

## **RXDA (Pin12)**

This is the UART receiver of the module. It is used to receive software commands and firmware update.

## **3D\_FIX (Pin13)**

The GPIO\_0 was assigned as fix flag output. If not used, keep floating.



## GP-3711 Data Sheet

Rev.A00

- Before 2D Fix

The GPIO\_A should continuously output one-second high-level with one-second low-level signal.

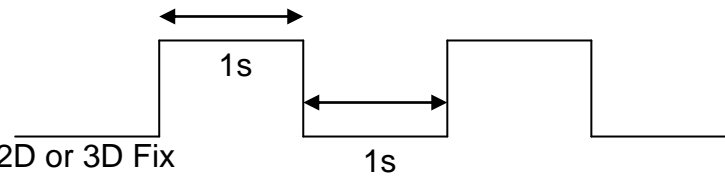

- After 2D or 3D Fix

The GPIO\_A should continuously output low-level signal.

Low \_\_\_\_\_

### BACKUP\_PWR (Pin14)

This is the backup power for GPS chipset to keep RTC running when main power is removed. For normal operation, the input voltage must be kept from 2.0V to 4.3V.

### VCC (Pin16)

3.3V  $\pm$  10% DC power supply input.

## GP-3711 Data Sheet

**NMEA Output Sentence**

**Table-1** lists each of the NMEA output sentences specifically developed and defined by MTK for use within MTK products

<b>NMEA Output Sentence</b>		<b>Table-1</b>
<b>Option</b>	<b>Description</b>	
GGA	Time, position and fix type data.	
GSA	GPS receiver operating mode, active satellites used in the position solution, and DOP values.	
GSV	The number of GPS satellites in view satellite ID numbers, elevation, azimuth, and SNR values.	
RMC	Time, date, position, course and speed data. Recommended Minimum Navigation Information.	
VTG	Course and speed information relative to the ground.	

## GP-3711 Data Sheet

Rev.A00

**GGA—Global Positioning System Fixed Data. Time, Position and fix related data for a GPS receiver**

**Table-2** contains the values for the following example :

\$GPGGA,064951.000,2307.1256,N,12016.4438,E,1,8,0.95,39.9,M,17.8,M,,\*65

GGA Data Format			Table-2
Name	Example	Units	Description
Message ID	\$GPGGA		GGA protocol header
UTC Time	064951.000		hhmmss.sss
Latitude	2307.1256		ddmm.mmmm
N/S Indicator	N		N=north or S=south
Longitude	12016.4438		dddmm.mmmm
E/W Indicator	E		E=east or W=west
Position Fix Indicator	1		See <b>Table-3</b>
Satellites Used	8		Range 0 to 14
HDOP	0.95		Horizontal Dilution of Precision
MSL Altitude	39.9	meters	Antenna Altitude above/below mean-sae-level
Units	M	meters	Units of antenna altitude
Geoidal Separation	17.8	meters	
Units	M	meters	Units of geoidal separation
Age of Diff. Corr.		second	Null fields when DGPS is not used
Checksum	*65		
<CR> <LF>			End of message termination

Position Fix Indicator		Table-3
Value	Description	
0	Fix not available	
1	GPS fix	
2	Differential GPS fix	

**GSA—GNSS DOP and Active Satellites**

**Table-4** contains the values for the following example :

\$GPGSA,A,3,29,21,26,15,18,09,06,10,,,,,2.32,0.95,2.11\*00

## GP-3711 Data Sheet

Rev.A00

<b>GSA Data Format</b>			<b>Table-4</b>
<b>Name</b>	<b>Example</b>	<b>Units</b>	<b>Description</b>
Message ID	\$GPGSA		GSA protocol header
Mode 1	A		See <b>Table-5</b>
Mode 2	3		See <b>Table-6</b>
Satellite Used	29		SV on Channel 1
Satellite Used	21		SV on Channel 2
....	....	....	....
Satellite Used			SV on Channel 12
PDOP	2.32		Position Dilution of Precision
HDOP	0.95		Horizontal Dilution of Precision
VDOP	2.11		Vertical Dilution of Precision
Checksum	*00		
<CR> <LF>			End of message termination

<b>Mode 1</b>		<b>Table-5</b>
<b>Value</b>	<b>Description</b>	
M	Manual—forced to operate in 2D or 3D mode	
A	2D Automatic—allowed to automatically switch 2D/3D	

<b>Mode 2</b>		<b>Table-6</b>
<b>Value</b>	<b>Description</b>	
1	Fix not available	
2	2D (< 4 SVs used)	
3	3D ( $\geq$ 4 SVs used)	

## GP-3711 Data Sheet

**GSV—GNSS Satellites in View**

**Table-7** contains the values for the following example :

\$GPGSV,3,1,09,29,36,029,42,21,46,314,43,26,44,020,43,15,21,321,39\*7D

\$GPGSV,3,2,09,18,26,314,40,09,57,170,44,06,20,229,37,10,26,084,37\*77

\$GPGSV,3,3,09,07,,,26\*73

GSV Data Format			Table-7
Name	Example	Units	Description
Message ID	\$GPGSV		GSV protocol header
Number of Messages	3		Range 1 to 3 <i>(Depending on the number of satellites tracked, multiple messages of GSV data may be required.)</i>
Message Number1	1		Range 1 to 3
Satellites in View	09		
Satellite ID	29		Channel 1 (Range 1 to 32)
Elevation	36	degrees	Channel 1 (Maximum 90)
Azimuth	029	degrees	Channel 1 (True, Range 0 to 359)
SNR (C/No)	42	dBHz	Range 0 to 99, (null when not tracking)
....	....	....	....
Satellite ID	15		Channel 4 (Range 1 to 32)
Elevation	21	degrees	Channel 4 (Maximum 90)
Azimuth	321	degrees	Channel 4 (True, Range 0 to 359)
SNR (C/No)	39	dBHz	Range 0 to 99, (null when not tracking)
Checksum	*7D		
<CR> <LF>			End of message termination

## GP-3711 Data Sheet

**RMC—Recommended Minimum Navigation Information**

**Table-8** contains the values for the following example :

\$GPRMC,064951.000,A,2307.1256,N,12016.4438,E,0.03,165.48,260406,,,A\*55

RMC Data Format			Table-8
Name	Example	Units	Description
Message ID	\$GPRMC		RMC protocol header
UTC Time	064951.000		hhmmss.sss
Status	A		A=data valid or V=data not valid
Latitude	2307.1256		ddmm.mmmm
N/S Indicator	N		N=north or S=south
Longitude	12016.4438		dddmm.mmmm
E/W Indicator	E		E=east or W=west
Speed Over Ground	0.03	knots	
Course Over Ground	165.48	degrees	True
Date	260406		ddmmyy
Magnetic Variation		degrees	E=east or W=west <i>(MTK does not support magnetic declination)</i>
Mode	A		A= Autonomous mode D= Differential mode E= Estimated mode
Checksum	*65		
<CR> <LF>			End of message termination

## GP-3711 Data Sheet

**VTG—Course and speed information relative to the ground.**

**Table-9** contains the values for the following example :

\$GPVTG,165.48,T,,M,0.03,N,0.06,K,A\*37

VTG Data Format			Table-9
Name	Example	Units	Description
Message ID	\$GPVTG		VTG protocol header
Course	165.48	degrees	Measured heading
Reference	T		True
Course		degrees	Measured heading
Reference	M		Magnetic ( <i>MTK does not support magnetic declination.</i> )
Speed	0.03	knots	Measured horizontal speed
Units	N		Knots
Speed	0.06	km/hr	Measured horizontal speed
Units	K		Kilometers per hour
Mode	A		A= Autonomous mode D= Differential mode E= Estimated mode
Checksum	*06		
<CR> <LF>			End of message termination